



**WE-YZC series High-power  
1550nm Fiber Amplifier Manual  
(With PON Port)**



**Hangzhou Prevail Optoelectronic Equipment Co., Ltd.**

**2014. 6 (Version 2)**

**Unicor s.a.**  
**Cordoba - Argentina**

[www.unicorsa.com.ar](http://www.unicorsa.com.ar)

# Table of Contents

Table of Contents .....	- 1 -
Foreword .....	- 2 -
1. Application .....	- 3 -
2. Performance Characteristics .....	- 3 -
3. Block diagram .....	- 4 -
4. Technique Parameter .....	- 4 -
4.1 Technique Parameter .....	- 4 -
4.2 Model and Power Comparison Table .....	- 6 -
5. External Function Description .....	- 7 -
5.1 Front Panel Description .....	- 7 -
5.2 Rear Panel Description .....	- 8 -
5.2.1 DC Power Module Introduction .....	- 8 -
6. Menu System .....	- 9 -
6.1 Main Menu .....	- 9 -
6.2 Display Menu .....	- 10 -
6.3 Setup Menu .....	- 11 -
6.4 Warning menu .....	- 12 -
7. Communication Setup Descriptions .....	- 13 -
7.1 Communication Interface Description .....	- 13 -
7.2 Set up the Hyper Terminal .....	- 14 -
8. Installation debugging .....	- 18 -
8.1 Unpack and Check .....	- 18 -
8.2 Instruments and tools .....	- 18 -
8.3 Installation steps .....	- 18 -
9. Clean and maintenance method of the optical fiber active connector .....	- 19 -
10. After-sales Service Description .....	- 20 -
11. Disclaimer .....	- 20 -

# Foreword

This manual applies to WE-YZC series Fiber Amplifier. It mainly describes the performance characteristics, technical parameters, installation and debugging, common troubleshooting, and other related content of the product. In order to ensure that the equipment can be successfully installed and safely operated, please read this manual carefully before installing and debugging the equipment. And the installation and debugging should be strictly according to the specified steps on the manual to avoid unnecessary damage to equipment or accident harm to the operator. Any questions, please contact with us in time.

## Special Tips:

- Er Yb Codoped Fiber Amplifier is high end professional equipment, and its installation and debugging must be operated by special technician. Read this manual carefully before operating to avoid damage to equipment caused by fault operation or accident harm to the operator.
- While the fiber amplifier is working, there is an invisible laser beam from the optical output adapter on the front panel. Avoiding permanent harm to the body and eye, the optical output should not aim at the human body and human should not look directly at the optical output with the naked eye!
- Please make sure that the ground terminal of the case and power outlet has been reliably grounding before turning on the power (Grounding resistance should be  $< 4\Omega$ ) to prevent the static damage the pump laser device and harm to human because of case charged.
- To ensure the equipment can work stable over a long time, in voltage unsteady or poor voltage wave region, it is recommend to the customer that he equips special AC regulated power supply, or even AC uninterruptible power supply (UPS) system for conditional users. In the region with large temperature variation environment (The equipment's ideal work environment temperature is 25 °C) or bad room

environment, it is recommended to the customer that he equips special air-conditioning system to improve the work environment.

## 1. Application

- Single-mode fiber 1550 amplification network
- FTTH network
- CATV network

## 2. Performance Characteristics

WE-YZ-C is a low noise high-performance Er Yb codoped fiber amplifier. Each output built-in CWDM (1310/1490/1550) wavelength division multiplexer. Conveniently multiplex the data stream of OLT and ONU to the fiber amplifier output by 1310nm and 1490nm optical connector. Thus reduced the equipment quantity, improved the system indexes and reliability. It is the ideal equipment for FTTx network, provides a flexible and low cost solution for the integration of three networks and the FTTH.

- Adopts Er Yb Codoped double-clad fiber technology;
- Output ports: 4-16 optional;
- Optical output power: total output up to 5W;
- Low noise figure: <5dB when input is 0dBm;
- Perfect network management interface, in line with standard SNMP network management;
- Intelligent temperature control system make the power consumption lower;

### 3. Block diagram

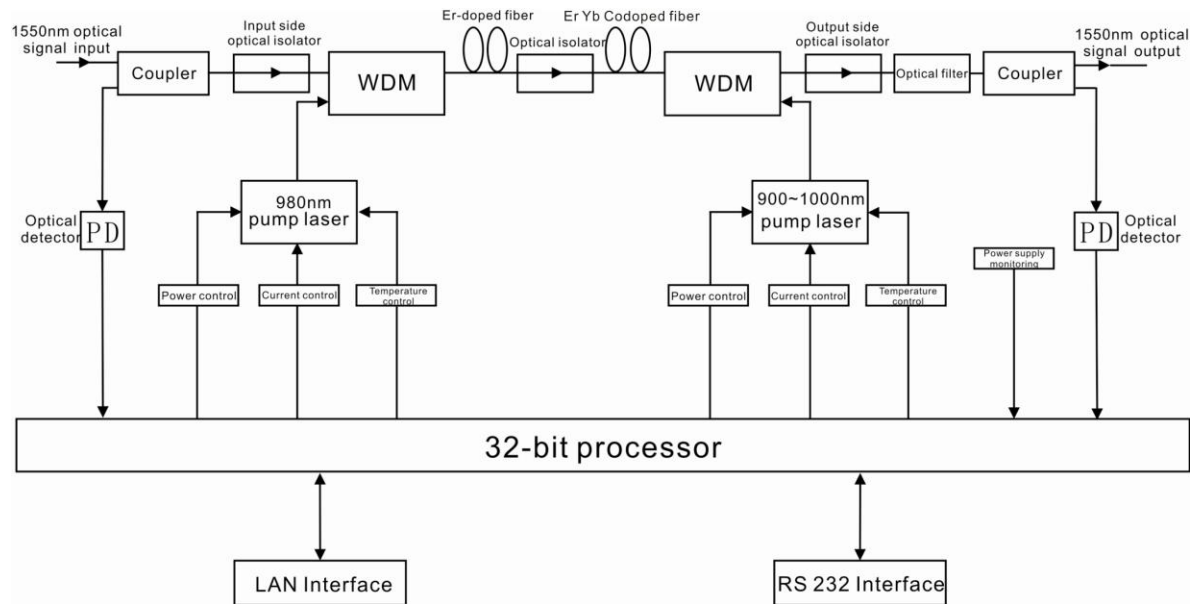

**Built-in WDM schematic diagram**

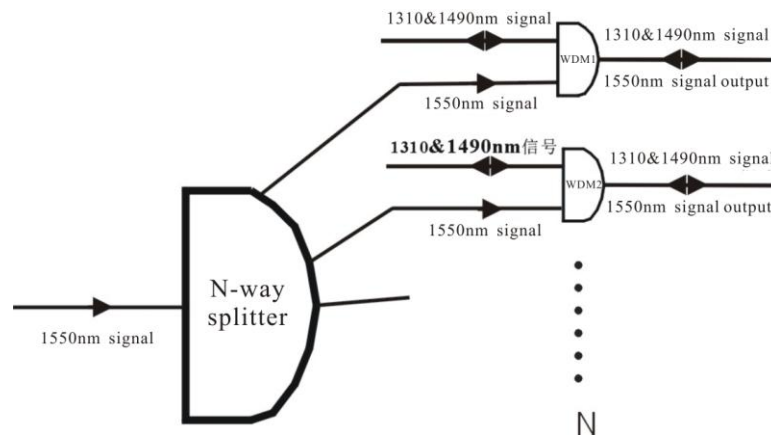

### 4. Technique Parameter

#### 4.1 Technique Parameter

Item	Unit	Technique parameters
CATV pass through wavelength	nm	1545 - 1565
PON pass through wavelength	nm	1260 - 1360 1480 - 1500
PON insertion loss	dB	<0.8
Isolation	db	>15
CATV optical input power range	dBm	-3 - +10
Maximum optical output power	dBm	37

Output power stability		dBm	±0.5	
Noise figure		dB	≤ 5.0 (Optical input power 0dBm, λ=1550nm)	
Return loss	Input	dB	≥ 45	
	Output	dB	≥ 45	
Optical Connector Type			SC/APC	
C/N		dB	≥ 50	Test condition according to GT/T 184-2002.
C/CTB		dB	≥ 63	
C/CSO		dB	≥ 63	
Power supply voltage		V	A: AC160V - 250V(50 Hz); B: DC48V	
Consumption		W	≤ 70	
Operating temperature range		°C	-10 - +42	
Maximum operating relative humidity		%	Max 95% no condensation	
Storage temperature range		°C	-30 - +70	
Maximum storage relative humidity		%	Max 95% no condensation	
Dimension		mm	483(L)× 440(W)× 88(H)	

## 4.2 Model and Power Comparison Table

Model	Total output power dBm	Output ports number	Output power per port dBm
WE-YZC-4 -18	25	4	18
WE-YZC-4 -19	26	4	19
WE-YZC-4 -20	27	4	20
WE-YZC-4 -21	28	4	21
WE-YZC-4 -22	29	4	22
WE-YZC-4 -23	30	4	23
WE-YZC-4 -24	31	4	24
WE-YZC-8 -15	26	8	15
WE-YZC-8 -16	27	8	16
WE-YZC-8 -17	28	8	17
WE-YZC-8 -18	29	8	18
WE-YZC-8 -19	30	8	19
WE-YZC-8 -20	31	8	20
WE-YZC-8 -21	32	8	21
WE-YZC-8 -22	33	8	22
WE-YZC-8 -23	34	8	23
* WE-YZC-8 -24	35	8	24
WE-YZC-16 -15	30	16	15
WE-YZC-16 -16	31	16	16
WE-YZC-16 -17	32	16	17
WE-YZC-16 -18	33	16	18
WE-YZC-16 -19	34	16	19
* WE-YZC-16 -20	35	16	20
* WE-YZC-16 -21	36	16	21
* WE-YZC-16 -22	37	16	22

The models with “\*” are ultra high power output EDFA.

## 5. External Function Description

### 5.1 Front Panel Description

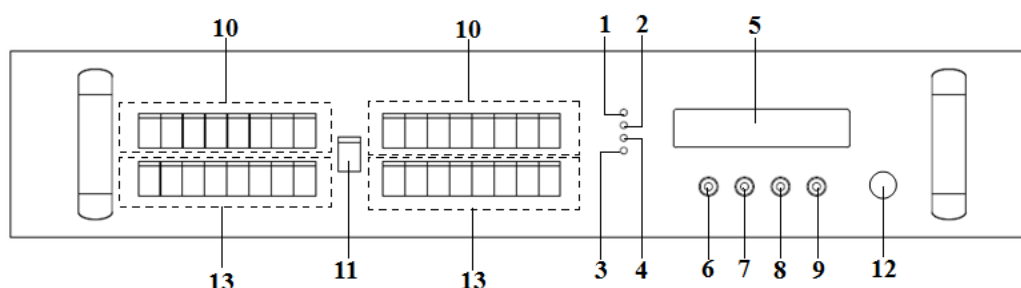

Schematic diagram of the front panel

- 1) Power indicator: One switching power supply is working – yellow; two switching power supplies are working – green.
- 2) Optical input power indicator: This light turns on when the optical input power is  $> -10\text{dBm}$ .
- 3) Pump working status indicator: Red light means the pump is not working, but the machine parameters are normal; flashing red light means the machine has broken down, related fault reason see the alarm menu of the display menu; green light means the pump is working normal.
- 4) Optical output power indicator: This light turns on when the optical output power is  $> +10\text{dBm}$ .
- 5)  $160 \times 32$  dot-matrix LCD screen: used to display all the parameters of the machine.
- 6) Display the exit or cancel key of the setup menu.
- 7) Display the up or increase key of the setup menu.
- 8) Display the down or decrease key of the setup menu.
- 9) Display the enter key of the setup menu.
- 10) 1310&1490nm signal in/out (PON port).
- 11) Optical signal input: The default connector type is SC/APC. Other specification requirements are specified by the customer.
- 12) Pump laser switching key: used to control the working status of pump laser. “ON” means the pump laser is open and “OFF” means the pump laser is closed. Ensure the key is on “OFF” position before power on. After passing self-test, rotate the key to “ON” position according to the displayed message.
- 13) Public port (COM port): This interface is the 1550nm signal output port of the device, also is the 1310&1490nm signal in/out port. Ports number: 4-16 optional.  
**Warning:** There is an invisible laser beam from this port while working normal. So the port should not be aligned to the human body or the naked eye to avoid accidental injury.



## 5.2 Rear Panel Description

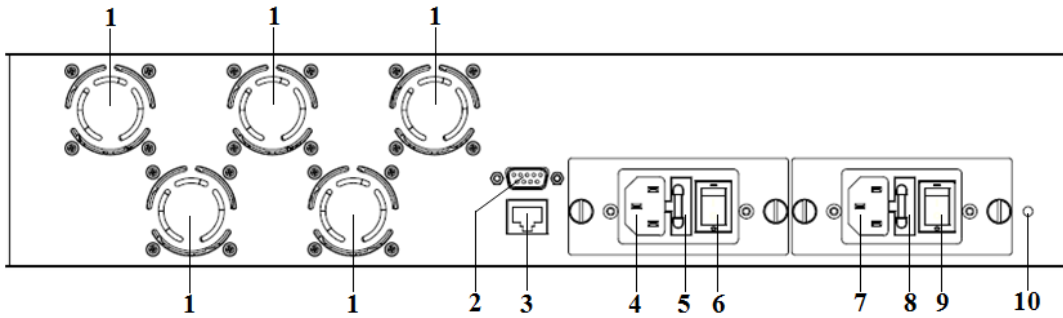

Schematic diagram of the rear panel

- 1) Fan outlet.
- 2) RS232 interface: Used for configuring the network management parameters.
- 3) LAN interface: correspond to IEEE802.3 10Base-T, used for network management.
- 4) The AC 220V input port of power supply 1.
- 5) The fuse of power supply 1.
- 6) The switch of power supply 1.
- 7) The AC 220V input port of power supply 2.
- 8) The fuse of power supply 2.
- 9) The switch of power supply 2.
- 10) Ground stud of the chassis: used for the connection of device and ground wire.

### 5.2.1 DC Power Module Introduction

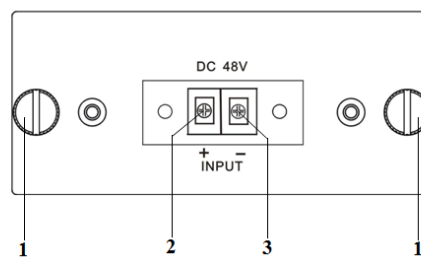

1	Mounting screws	2	+ Positive terminal block	3	- Negative terminal block
---	-----------------	---	---------------------------	---	---------------------------

## 6. Menu System

### 6.1 Main Menu

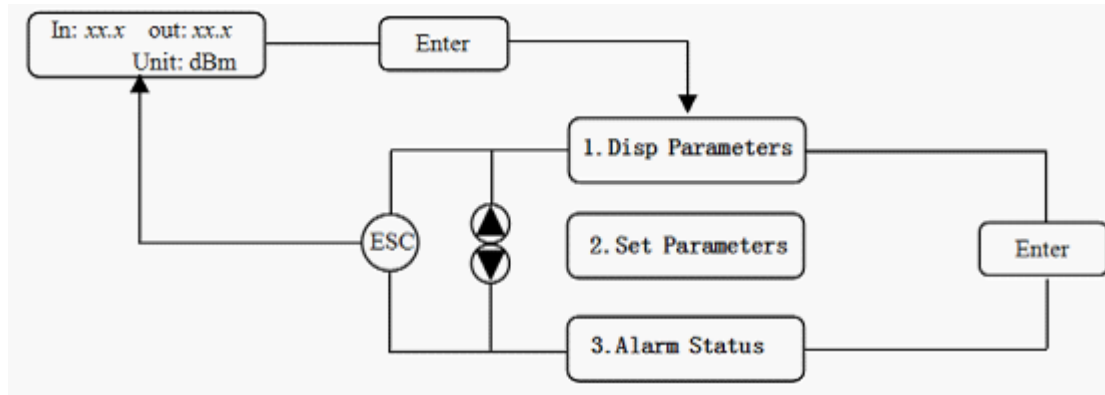

Name	display	discription
System Starting	xxxxxx	Manufacturers' logo
	xxxxxx	Equipment model
	xxxxxx	Start countdown / lock status
Suspend Page	In: xx.x out: xx.x Unit: dBm	Display the optical input / output power
Main Page	1.Disp Parameters	Entry of parameter display menu
	2.Set Parameters	Entry of parameter setup menu
	3.Alarm Status	Entry of alarm information menu

## 6.2 Display Menu

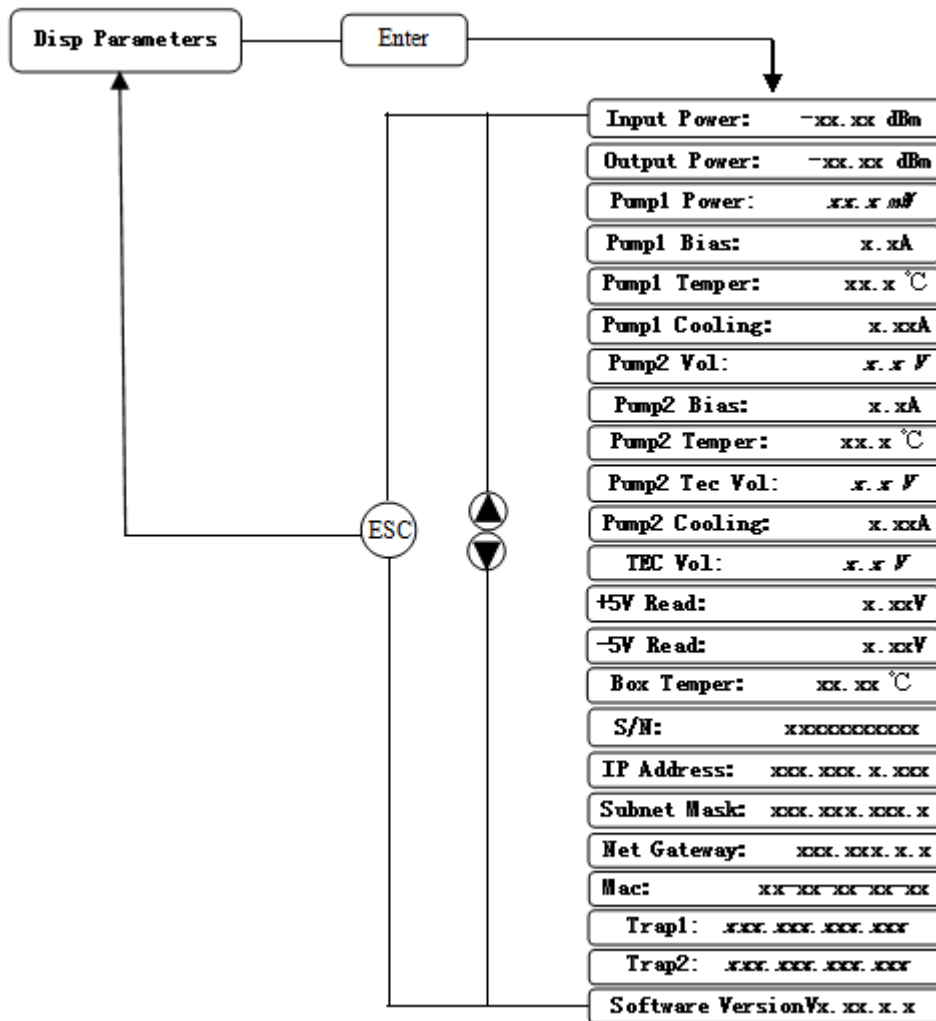

<b>1.Disp Parameters</b>	Input Power: xx.x dBm	Input power, accurate to 0.1 dBm
	Output Power: xx.x dBm	Output power, accurate to 0.1 dBm
	Pump1 Power: xx.x mW	Power of pump1, accurate to 0.1 dBm
	Pump1 Bias: x.x A	Bias current of pump1, accurate to 0.1 A
	Pump1 Temper: xx.x °C	Temperature of pump1, accurate to 0.1 °C
	Pump1 Cooling: x.xx A	Cooling current of pump1, accurate to 0.01 A
	Pump2 Vol: x.x V	Drive voltage of pump2, accurate to 0.1 V
	Pump2 Bias: x.x A	Bias current of pump2, accurate to 0.1 A
	* Pump2 Temper: xx.x °C	Temperature of pump2, accurate to 0.1 °C
	* Pump2 Tec Vol: x.x V	Cooling voltage of pump2, accurate to 0.1 V
	* Pump2 Cooling: x.xx A	Cooling current of pump2, accurate to 0.01 A
	TEC Vol: x.x V	The first stage voltage of pump2 cooler, 0.1 V
	+5V Read: x.x V	+5V power supply voltage, accurate to 0.1 V
	-5V Read: -x.x V	-5V power supply voltage, accurate to 0.1 V
	Box Temper: xx.x °C	Box temperature, accurate to 0.1 °C
	S/N: xxxxxxxx	Device serial number

	IP Address: xxx.xxx.xxx.xxx	IP address
	Subnet Mask:xxx.xxx.xxx.xxx	Subnet mask
	Net Gateway:xxx.xxx.xxx.xxx	Gateway
	Mac: xxxxxxxxxxxx	Physical address
	Trap1: xxx.xxx.xxx.xxx	trap1 address
	Trap2: xxx.xxx.xxx.xxx	trap2 address
	Software Version: Vx.xx.x.x	Firmware version number

The ultra high power output EDFA no the “\*” menu.

### 6.3 Setup Menu

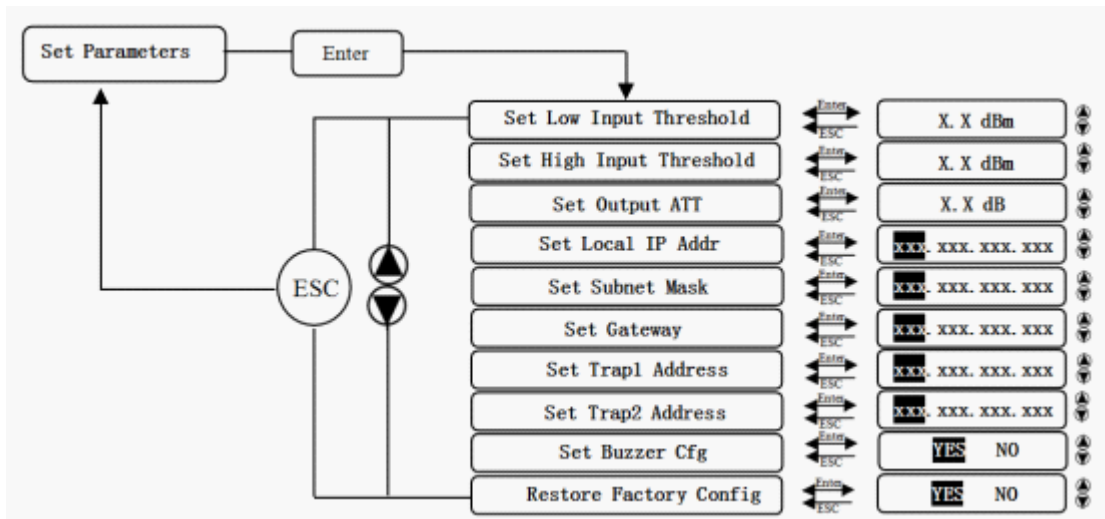

<b>2.Set Parameters</b>	Set Low Input Threshold	Set the low optical input power alarm threshold, range -3.0~10.0dBm
	Set High Input Threshold	Set the high optical input power alarm threshold , range -3.0~10.0dBm
	*Set Output ATT	Set the optical output power attenuation
	Set Local IP Addr	Set IP address
	Set Subnet Mask	Set subnet mask
	Set Gateway	Set gateway
	Set Trap1 Address	Set trap1
	Set Trap2 Address	Set trap2
	Set Buzzer cfg	Set the switch of beeper
	Restore Factory config	Restore the factory configuration, set content as shown above

The ultra high power output EDFA no the “\*” menu.

## 6.4 Warning menu

<b>3.Alarm Status</b>	Input Status: xxx	xxx= <i>LOLOW</i> :	Very low optical input power alarm
		xxx= <i>LOW</i> :	Low optical input power alarm
		xxx= <i>HIGH</i> :	High optical input power alarm
		Xxx= <i>HIHIGH</i> :	Very high optical input power alarm
	Output Status: xxx	xxx= <i>LOLOW</i> :	Very low optical output power alarm
		xxx= <i>LOW</i> :	Low optical output power alarm
		xxx= <i>HIGH</i> :	High optical output power alarm
		Xxx= <i>HIHIGH</i> :	Very high optical output power alarm
	Pumpx Power: xxx	xxx= <i>LOLOW</i> :	Very low power of pump x alarm
		xxx= <i>LOW</i> :	Low power of pump x alarm
		xxx= <i>HIGH</i> :	High power of pump x alarm
		Xxx= <i>HIHIGH</i> :	Very high power of pump x alarm
	Pumpx Bias: xxx	xxx= <i>LOLOW</i> :	Very low bias current of pump x alarm
		xxx= <i>LOW</i> :	Low bias current of pump x alarm
		xxx= <i>HIGH</i> :	High bias current of pump x alarm
		Xxx= <i>HIHIGH</i> :	Very high bias current of pump x alarm
	Pumpx Temper: xxx	xxx= <i>LOLOW</i> :	Very low temperature of pump x alarm
		xxx= <i>LOW</i> :	Low temperature of pump x alarm
		xxx= <i>HIGH</i> :	High temperature of pump x alarm
		Xxx= <i>HIHIGH</i> :	Very high temperature of pump x alarm
	Pumpx Tec: xxx	xxx= <i>LOLOW</i> :	Very low cooling current of pump x alarm
		xxx= <i>LOW</i> :	Low cooling current of pump x alarm
		xxx= <i>HIGH</i> :	High cooling current of pump x alarm
		Xxx= <i>HIHIGH</i> :	Very high cooling current of pump x alarm
	+5V Status: xxx	xxx= <i>LOLOW</i> :	Very low +5V DC power supply alarm
		xxx= <i>LOW</i> :	Low +5V DC power supply alarm
		xxx= <i>HIGH</i> :	High +5V DC power supply alarm
		Xxx= <i>HIHIGH</i> :	Very high +5V DC power supply alarm
	-5V Status: xxx	xxx= <i>LOLOW</i> :	Very low -5V DC power supply alarm
		xxx= <i>LOW</i> :	Low -5V DC power supply alarm
		xxx= <i>HIGH</i> :	High -5V DC power supply alarm
		Xxx= <i>HIHIGH</i> :	Very high -5V DC power supply alarm
Device Temper: xxx	xxx= <i>LOLOW</i> :	Very low chassis temperature alarm	
	xxx= <i>LOW</i> :	Low chassis temperature alarm	
	xxx= <i>HIGH</i> :	High chassis temperature alarm	
	xxx= <i>HIHIGH</i> :	Very high chassis temperature alarm	

## 7. Communication Setup Descriptions

### 7.1 Communication Interface Description

1) RS232 communication interface

Adopt DB9 standard connector, the pin definitions as follow:

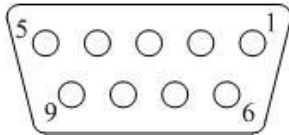

1: No Connect	2: TX	3: RX
4: No Connect	5: GND	6: No Connect
7: No Connect	8: No Connect	9: No Connect

The serial communication uses the standard NRZ form, 1 starts bit, 8 data bits, 1 stop bit and the baud rate is 38400.

2) LAN communication interface

Adopt RJ45 standard connector, the pin definitions as follow:

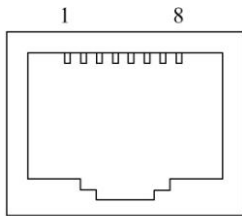

LAN

1: TX+	2: TX-	3: RX+
4: No Connect	5: No Connect	6: RX-
7: No Connect	8: No Connect	

## 7.2 Set up the Hyper Terminal

If you have not set up the Hyper Terminal in your Windows system, follow these steps:

Click “start menu→program→accessory→communication→ Hyper Terminal”;

This results in the following screen:



Then you input your connection name, such as “SNMP38400”; and choose the serial port to connect with your equipment. As follows:



Press the “OK” button shows the configuration page of serial port. As follows:



Change the serial port configuration to 38400-baud rate, 8 data bits, no parity bit, 1 stop bit, no data flow control, press the “OK” key, you have set up the Windows serial port Hyper Terminal.

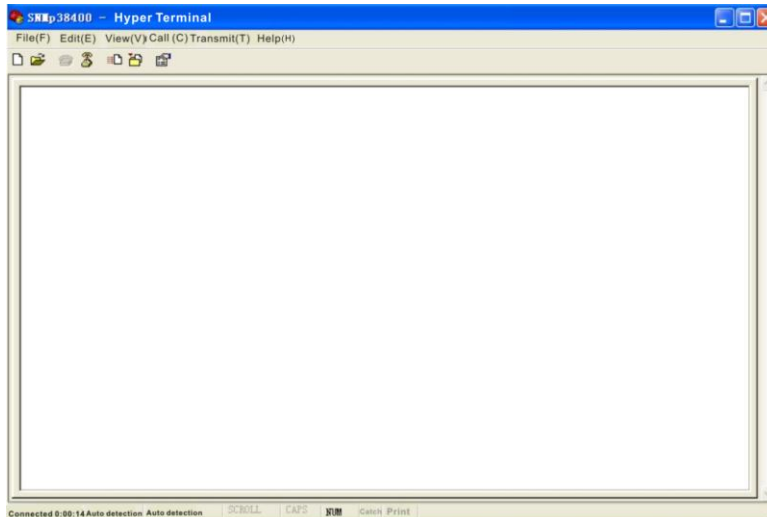

You can click “file→save” menu to save this configuration of Hyper Terminal for later using.

## Operating Parameter Configuration

Under the condition of power off, use the serial port lines to connect the RS232 port with the computer port. Open the Windows Hyper Terminal which you have set up. Then turn on the power, you will see the page as follows:



The application program starts normally. You can input your command in this page, and then configure the operating parameter of the application program.

### System supports the following commands:

- |                |  |
|----------------|--|
| <b>help</b>    | <b>List internal commands of the system;</b>               |
| <b>ethcfg</b>  | <b>Configure the Ethernet operating parameter;</b>         |
| <b>settrap</b> | <b>Configure the aim host IP address of the SNMP Trap;</b> |
| <b>setatt</b>  | <b>Show or modify the output attenuation.</b>              |



## Specific use as follows:

### help

This command is used to show the current application program internal orders list as follows:

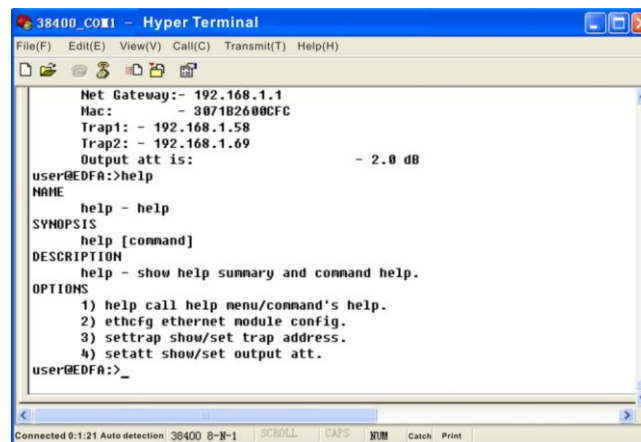

```
38400_CO11 - Hyper Terminal
File(F) Edit(E) View(V) Call(C) Transmit(T) Help(H)
Net Gateway:- 192.168.1.1
Mac: - 3071B2600CFC
Trap1: - 192.168.1.58
Trap2: - 192.168.1.69
Output att is: - 2.0 dB
user@EDFA:>help
NAME
help - help
SYNOPSIS
help [command]
DESCRIPTION
help - show help summary and command help.
OPTIONS
1) help call help menu/command's help.
2) ethcfg ethernet module config.
3) settrap show/set trap address.
4) setatt show/set output att.
user@EDFA:>_
```

You can also use the “help” command to show help information of other orders, such as “help ethcfg”, ethcfg’s help information appears as follows:

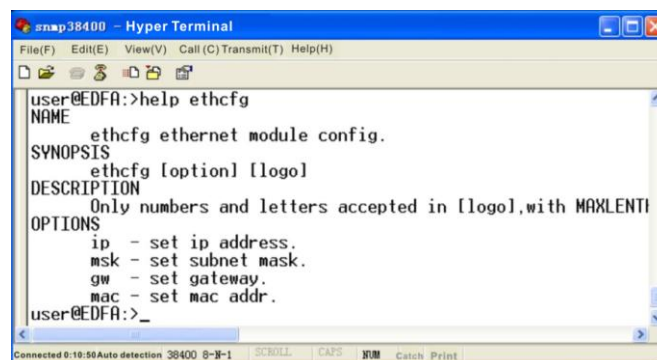

```
snap38400 - Hyper Terminal
File(F) Edit(E) View(V) Call(C) Transmit(T) Help(H)
user@EDFA:>help ethcfg
NAME
ethcfg ethernet module config.
SYNOPSIS
ethcfg [option] [logo]
DESCRIPTION
Only numbers and letters accepted in [logo],with MAXLENTI
OPTIONS
ip - set ip address.
msk - set subnet mask.
gw - set gateway.
mac - set mac addr.
user@EDFA:>_
```

### ethcfg

This command configures the Ethernet parameters, including IP address, subnet mask, gateway and physical address. You can refer to the help information for its using.

Direct input the command “ethcfg” as follow to see the parameters:

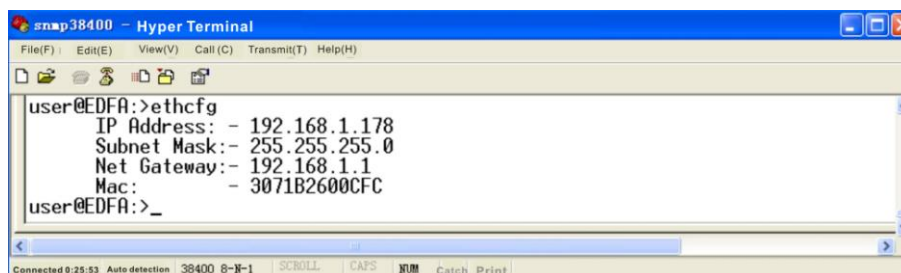

```
snap38400 - Hyper Terminal
File(F) Edit(E) View(V) Call(C) Transmit(T) Help(H)
user@EDFA:>ethcfg
IP Address:- 192.168.1.178
Subnet Mask:- 255.255.255.0
Net Gateway:- 192.168.1.1
Mac: - 3071B2600CFC
user@EDFA:>_
```

To set the IP address:

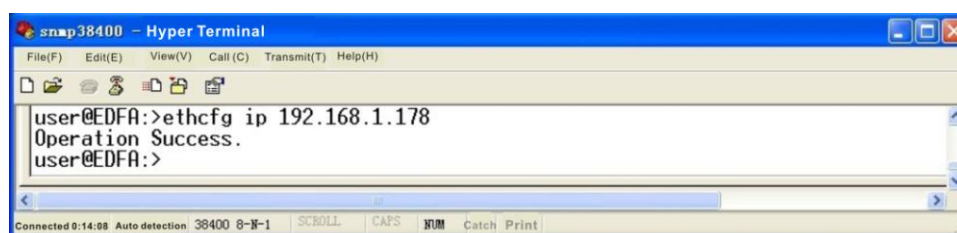

```
snap38400 - Hyper Terminal
File(F) Edit(E) View(V) Call(C) Transmit(T) Help(H)
user@EDFA:>ethcfg ip 192.168.1.178
Operation Success.
user@EDFA:>
```

## settrap

This command shows or modifies the aim host IP address lists of the SNMP Trap, “settrap” command is used to display the current configured trap IP, as follows:

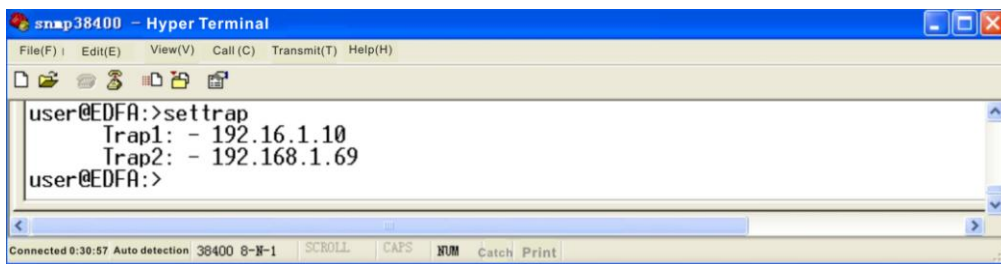

```
snmp38400 - Hyper Terminal
File(F) Edit(E) View(V) Call(C) Transmit(T) Help(H)
user@EDFA:>settrap
  Trap1: - 192.16.1.10
  Trap2: - 192.168.1.69
user@EDFA:>
```

trap IP address set as follows:



```
snmp38400 - Hyper Terminal
File(F) Edit(E) View(V) Call(C) Transmit(T) Help(H)
user@EDFA:>help settrap
NAME
  settrap show/set trap address.
SYNOPSIS
  settrap [option] [trap address]
DESCRIPTION
  set or display trap address.
OPTIONS
  1 - set trap1 address.
  2 - set trap2 address.
user@EDFA:>settrap 1 192.16.1.10
Operation Success.
user@EDFA:>
```

## setatt

This command is used to show or modify the output attenuation. Specific use as follows:

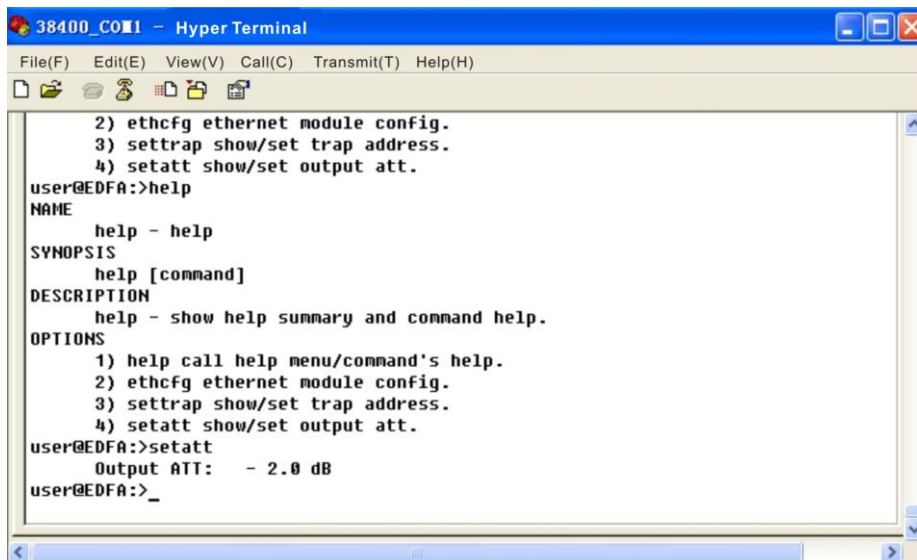

```
38400_CO#1 - Hyper Terminal
File(F) Edit(E) View(V) Call(C) Transmit(T) Help(H)
2) ethcfg ethernet module config.
3) settrap show/set trap address.
4) setatt show/set output att.
user@EDFA:>help
NAME
  help - help
SYNOPSIS
  help [command]
DESCRIPTION
  help - show help summary and command help.
OPTIONS
  1) help call help menu/command's help.
  2) ethcfg ethernet module config.
  3) settrap show/set trap address.
  4) setatt show/set output att.
user@EDFA:>setatt
Output ATT: - 2.0 dB
user@EDFA:>_
```

The attenuation range is 0-3dB.

## 8. Installation debugging

### 8.1 Unpack and Check

1. Insure the package is not defaced. If it has any damage or water mark, please contact local agency or carrier.
2. After unpacking, check equipments and accessories according to package list. Any question, please contact local agency or our company.
3. If you think the equipment has been damaged, please don't electrify to avoid worse damage. Please contact local agency or our company in time.

### 8.2 Instruments and tools

1. An optical power meter;
2. A digital multimeter;
3. A standard optical fiber test jumper (SC/APC);
4. Some absolute alcohol and medical cotton wool;

### 8.3 Installation steps

1. Before installing the equipment, please read the <User's manual> carefully and install the equipment according to the <User's manual>. **Note:** For the man-made damage and other all consequence caused by error installation that not according to the <User's manual>, we will not be responsible and will not supply free warranty.
2. Take out the device from the box; fix it to the rack and reliably grounding. (The grounding resistance must be  $< 4\Omega$ ).
3. Use the digital multimeter to check the supply voltage, make sure the supply voltage comply with the requirements and the switch key is on the "OFF" position. Then connect the power supply.
4. Input the optical signal according to the display message. Turn the switch key to the "ON" position and observe the front panel LED status. After the pump working status indicator turn into green, the device is working normal. Then press the menu button on the front panel to check the working parameters.
5. Connect the optical power meter to the optical signal output end by the standard optical fiber test jumper, then measure the optical output power. Affirm the measured optical output power and the displayed power are the same and have reached the nominal value. (Affirm the optical power meter is on 1550nm wavelength test position; the optical fiber test jumper is the matched one and on the connector surface has no pollution.) Remove the standard optical fiber test jumper and optical power meter; connect the device to the network. So far, the device has been completely installed and debugged.

## **9. Clean and maintenance method of the optical fiber active connector**

In many times, we consider the decline of the optical power as the equipment faults, but actually it may be caused by that the optical fiber connector was polluted by dust or dirt. Inspect the fiber connector, component, or bulkhead with a fiberscope. If the connector is dirty, clean it with a cleaning technique following these steps:

1. Turn off the device power supply and carefully pull off the optical fiber connector from the adapter.
2. Wash carefully with good quality lens wiping paper and medical absorbent alcohol cotton. If use the medical absorbent alcohol cotton, still need to wait 1~2 minutes after wash, let the connector surface dry in the air.
3. Cleaned optical connector should be connected to optical power meter to measure optical output power to affirm whether it has been cleaned up.
4. When connect the cleaned optical connector back to adapter, should notice to make force appropriate to avoid china tube in the adapter crack.
5. If the optical output power is not normal after cleaning, should pull off the adapter and clean the other connector. If the optical power still low after cleaning, the adapter may be polluted, clean it. (Note: Be carefully when pull off the adapter to avoid hurting inside fiber.)
6. Use compressed air or degrease alcohol cotton to wash the adapter carefully. When use compressed air, the muzzle aims at china tube of the adapter, clean the china tube with compressed air. When use degrease alcohol cotton, insert directions need be consistent, otherwise can't reach a good clean effect.

### **Special notice:**

- a. **In the process of clean the active optical fiber connector, you should avoid direct shining at eye, which will cause permanence burn!!!!**
- b. **Use proper energy to install the active optical connector, or the ceramic tape in the adaptor will lead to break. Once the ceramic tape is broken, the optical output power will decrease rapidly. And turn the active optical fiber connector slightly, the optical output power changes obviously.**
- c. **Please operate the optical fiber under the condition of shut off the pump laser. Or the high output power will lead to burn the joint of the optical output fiber, which will cause the output power decrease.**

## **10. After-sales Service Description**

1. If the equipment fault is resulted from the users' improperly operation or unavoidable environment reasons, we will responsible maintenance but ask suitable material cost.
2. When the equipment breaks down, immediately contact local distributor or directly call our technical support hotline 86-0571-82576002, 18967160936.
3. The site maintenance of the fault equipment must be operated by professional technicians to avoid worse damage.

**Special notice:** If the equipment has been maintained by users, we will not responsible free maintenance. We will ask suitable maintenance cost and material cost.

## **11. Disclaimer**

We reserve the right to change any products described herein at any time, and without prior notice. We assume no responsibility or liability arising from the use of the products described herein, except as expressly agreed to in writing by us. The use and purchase of this product does not convey a license under any patent rights, copyrights, trademark rights, or any intellectual property rights of us. Nothing hereunder constitutes a representation or warranty that using any products in the manner described herein will not infringe any patents of third parties.